

(No Model.)

2 Sheets—Sheet 1.

E. S. STEHMAN.
WATCH MAKER'S LATHE:

No. 463,750.

Patented Nov. 24, 1891.

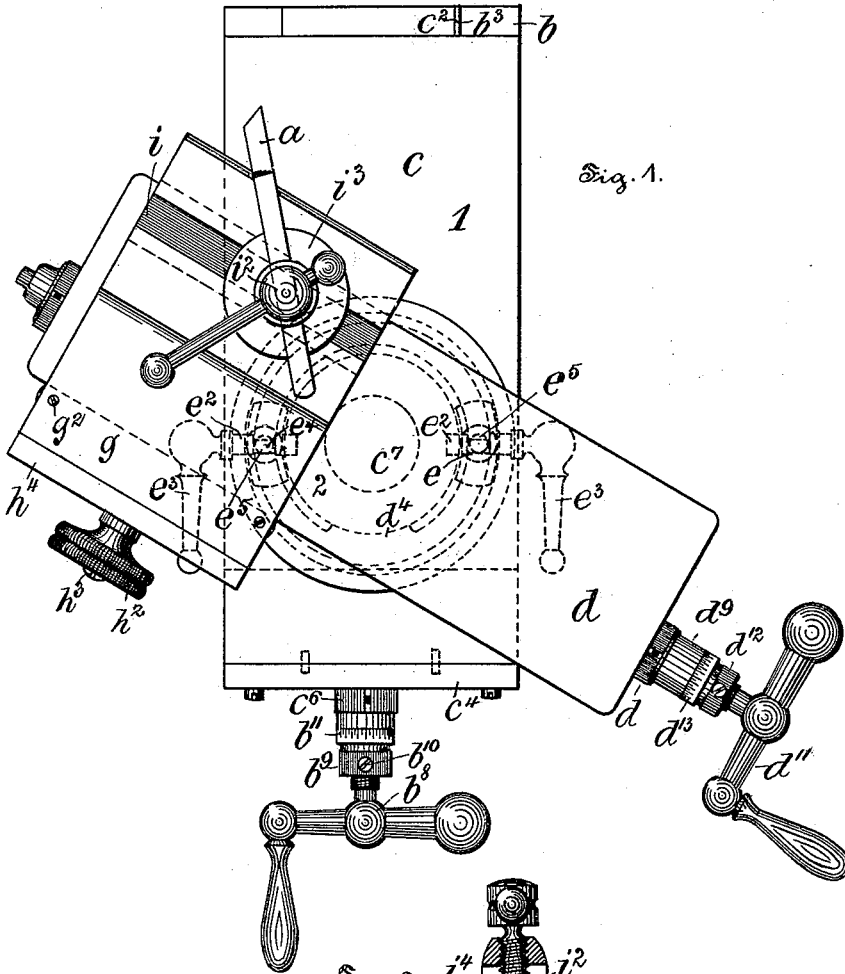

Fig. 1.

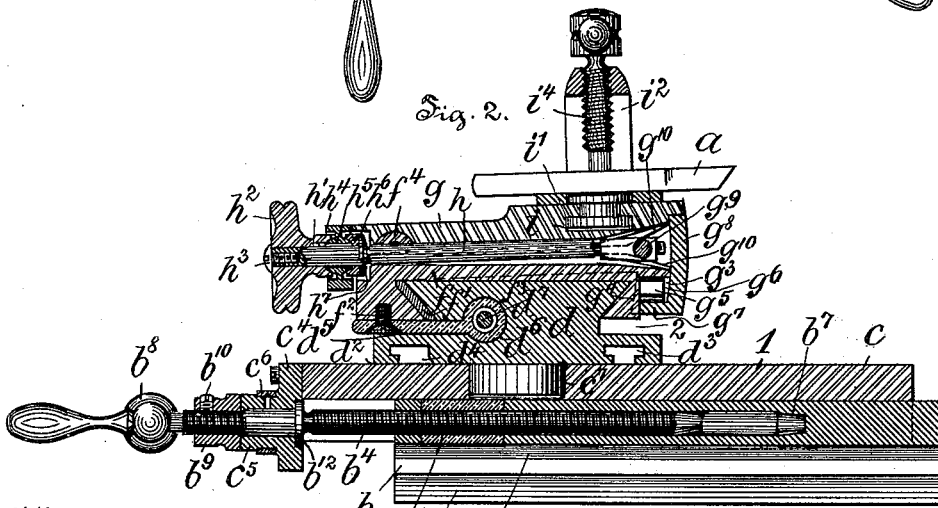

Fig. 2.

Witnesses:
Hermann Bormann.
Thomas M. Smith.

Inventor:
Edward S. Stehman,
by J. Walter Douglass.

Oct. 24.

(No Model.)

2 Sheets—Sheet 2.

E. S. STEHMAN.
WATCH MAKER'S LATHE.

No. 463,750.

Patented Nov. 24, 1891.

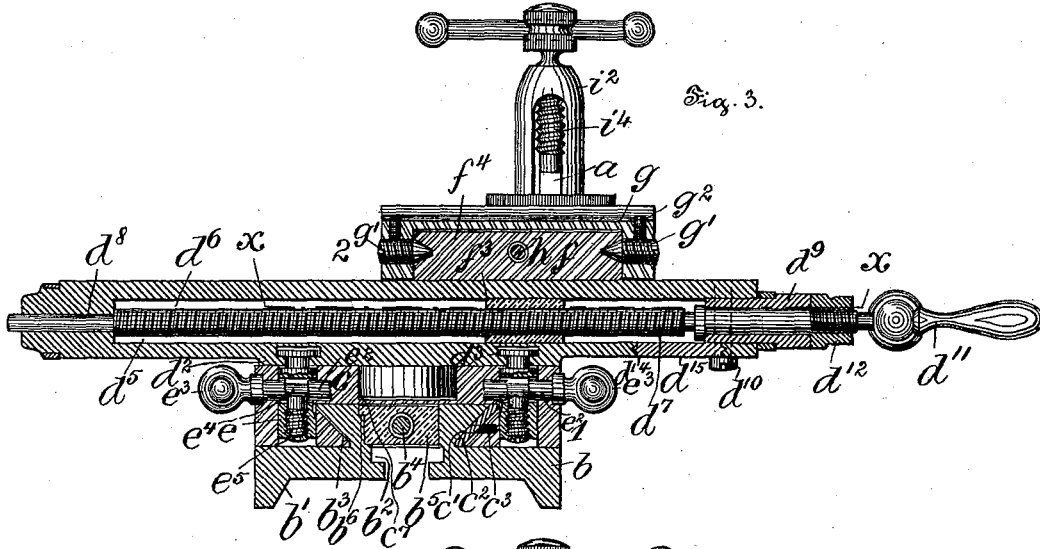

Fig. 3.

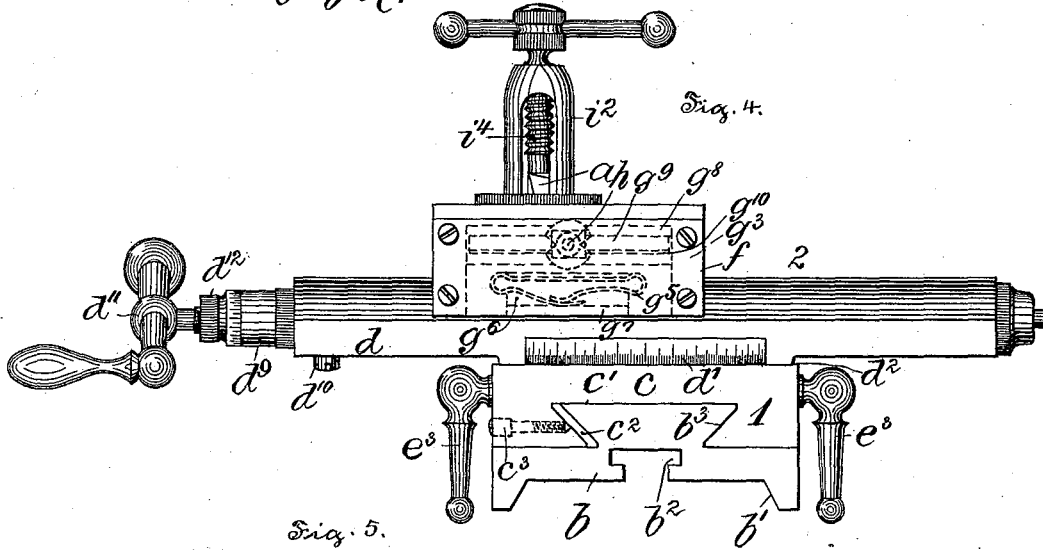

Fig. 4.

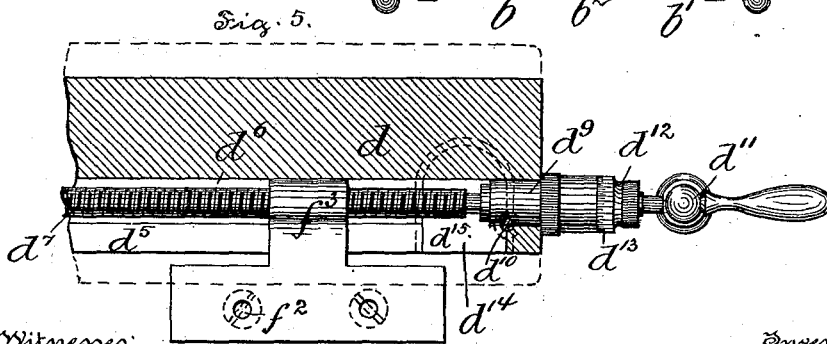

Fig. 5.

Witnesses:
Kunemann Bormann,
Thomas M. Smith

Inventor:
Edward S. Stehman,
by J. Walter Douglass.
att'y.

UNITED STATES PATENT OFFICE.

EDWARD STEWART STEHMAN, OF LANCASTER, PENNSYLVANIA, ASSIGNOR
TO STEHMAN, JENKS & STEHMAN, OF SAME PLACE.

WATCH-MAKER'S LATHE.

SPECIFICATION forming part of Letters Patent No. 463,750, dated November 24, 1891.

Application filed June 16, 1891. Serial No. 396,433. (No model.)

To all whom it may concern:

Be it known that I, EDWARD STEWART STEHMAN, a citizen of the United States, residing at Lancaster, in the county of Lancaster and State of Pennsylvania, have invented certain new and useful Improvements in Watch-Makers' and Jewelers' Lathes, of which the following is a specification.

The present invention relates, in general, to watch-makers' and jewelers' lathes, and more particularly to certain devices and combinations of devices comprising the accessories of the tool-rest.

The principal object of the present invention is to provide simple, comparatively inexpensive, and durable means for accurately adjusting, feeding, and directing the tool in any required direction; and to this end the invention consists in the improvements hereinafter fully described, and particularly pointed out in the claims.

The nature and characteristic features of the invention will be more fully understood from the following description, taken in connection with the accompanying drawings, forming part hereof, in which—

Figure 1 is a top or plan view of a tool-rest having adjusting and feeding devices embodying the invention applied thereto. Fig. 2 is a central section of the same. Fig. 3 is a central section of the same, taken in a plane at right angles to the intercepting plane of Fig. 2. Fig. 4 is an elevation of the tool-rest as seen from the back of the lathe, showing some of the working parts in dotted lines; and Fig. 5 is a horizontal section on the line $x x$ of Fig. 3.

In the drawings, a is the tool, and b is the bed-plate of the carrier. The tool a may be of any preferred or suitable form and material, and the bed-plate b may be provided with ways b' for sliding upon the tool-rest carrier (not shown) and with a slot b^2 for engaging the head of the tool-rest spindle, (not shown,) so that the tool a may be rapidly brought into close proximity with the work by sliding the tool-rest carrier on and lengthwise of the lathe-bed, thus shifting the tool longitudinally of the lathe, and by sliding the bed-plate b on the tool-rest carrier, thus shifting the tool a transversely of the lathe. After the tool a is brought into proximity

with the work the bed-plate b and tool-rest carrier are clamped to place upon the lathe-bed. It will be understood that the above-described adjustments serve only to bring the tool-rest as a whole into operative position—that is, into such a position that the point of the tool a will be in close proximity with the work, but not in contact therewith. Moreover, these adjustments are well understood and do not form part of the present invention, which relates to the slow and accurate adjustment and feed of the point of the tool during the operation of the lathe and with reference to the bed-plate b of the tool-rest, as has been before stated.

Having thus briefly indicated one manner in which the tool-rest may be applied to a lathe, a description will now be given of my improved tool-rest.

For convenience of description the tool-rest may be considered as comprising a lower portion 1 and an upper portion 2, and these two portions are pivoted together, as will be hereinafter described.

Referring to the lower portion 1, the bed-plate b , so far as concerns the description of the tool-rest, may be considered as fixed, because the adjustments and feeding devices of the tool-rest are not brought into requisition or use for operating the tool a with reference to the work until the bed-plate b has been clamped to place upon the lathe-bed, as has been already stated. This bed-plate b is provided upon the upper surface thereof with ways b^3 , for a purpose to be presently described, and also with a feed-screw b^4 , supported by and working in and through a suitable nut b^5 , attached to the bed-plate b by a key and slot b^6 . One extremity of the feed-screw b^4 is turned off smooth and adapted to engage a suitable seat b^7 , and the other extremity of the feed-screw b^4 is provided with a counterbalanced handle b^8 and with a collar b^9 screwed onto a suitable thread and held to place by a set-screw b^{10} . The perimeter of the collar b^9 is graduated, as at b^{11} , to enable the operator to operate the feed-screw b^4 accurately. c is a sliding plate provided with a wedge-shaped slot c' , adapted to engage and slide upon the ways b^3 . The slot c' is preferably made larger than the ways b^3 , and the space so formed is filled by a strip c^2 ,

loosely pinned, as at c^3 , to one of the side walls of the slot. c^3 are set-screws accessible from the exterior of the sliding plate and adapted to permit of the adjustment of the strip c^2 , so as to insure a good sliding fit between the bed-plate b and sliding plate c . c^4 is a yoke in which the feed-screw b^4 may be freely rotated. However, the feed-screw b^4 is held against end-play in the yoke c^4 by means of the collar b^8 and a flange b^{12} . The yoke c^4 is also provided with an annular projection c^5 , having an oil-hole therein and provided with a movable split-ring c^6 for closing or opening the oil-hole. This yoke is pinned and screwed to the forward extremity of the sliding plate c , so that the rotation of the feed-screw b^4 causes the same to be shifted endwise through the nut b^5 , and the endwise motion of the feed-screw is imparted to the sliding plate c , so that the latter is caused to travel upon the bed-plate b , and the ways b^3 , wedge-shaped slot c' , and adjustable strip c^2 constrain the plate c to move or slide in a straight line. The upper portion of the sliding plate c is provided with a circular socket c^7 , for a purpose to be presently described.

Referring now to the upper portion of the tool-rest, a pivot connected with a rotating plate d fits into the socket c^7 and serves to connect the parts 1 and 2. This plate d is also provided with an annular bearing-surface d^2 , which works upon the upper surface of the plate c , so that the axis of rotation of the plate d is always vertical. The perimeter of this annular bearing-surface is graduated, as at d' , in order to facilitate the operation of adjusting the tool. The plates c and d may be clamped together by means of dogs e . The head of these dogs e are flattened and are inserted into a circular internally-expanded slot d^3 , cut or otherwise formed in the under side of the plate d by means of an enlargement d^4 in the slot d^3 , so that after the dogs are inserted into the slot the heads of the dogs engage the slot, but in such manner as to be normally free to travel therein. The shanks of the dogs e are provided with enlarged or slightly-oblong apertures and are inserted into suitable holes in the plate c . e^2 are spindles provided with handles e^3 and with cams e^4 and suitably supported in holes communicating with and ranging transversely of the holes which carry the shanks of the dogs. e^5 are screws inserted axially into the extremities of the shanks of the dogs and adapted to engage the cams e^4 , so that the rotation of the spindles causes the cams to engage the screw e^5 of the dogs, whereby the latter are drawn downward, and the downward motion of the dogs causes the heads thereof to clamp the plate d in position upon the plate c . Moreover, the degree of pressure exerted by the cams may be increased or diminished by means of the screw e^5 . One edge of the rotating plate d is provided with a slot d^5 , extending near to but not through or past the respective extremities thereof, and

this slot d^5 communicates with an internal chamber d^6 , in which is mounted a feed-screw d^7 . This feed screw d^7 is supported at one extremity thereof in bearings d^8 , formed integral with the plate d , and at or near the other extremity thereof in a bushing d^9 , inserted into the open end of the chamber d^6 and secured to place therein by means of a screw d^{10} . This feed-screw d^7 is provided with a handle d^{11} and with a thimble d^{12} , having a graduated scale d^{13} upon the perimeter thereof, in order to permit of the accurate rotation of the feed-screw. f is a traveler adapted to engage with and slide upon suitable wedge-shaped ways formed upon the rotating plate d . f' is a strip interposed between the plate d and traveler f and loosely pinned to the traveler f and supported by adjusting-screws. This strip f' insures a snug and accurate sliding fit between the plate d and traveler f . f^3 is a nut traveling endwise of and on the feed-screw d^7 and provided with an extension which works in the slot d^5 and is attached to the traveler f by means of screws f^2 . This nut f^3 may be made of brass or other preferred material, and is inserted into the slot d^5 by means of a transversely-ranging slot d^{14} , Fig. 5, cut or otherwise formed in the under side of the plate d and provided with a removable cover d^{15} . This cover d^{15} may be conveniently retained in a closed position by means of the screw d^{10} . g is an oscillating plate pivotally attached to the traveler f by means of the screws g' , having conical points engaging suitable centers or bearings cut or otherwise formed in a bead f^4 upon the traveler f . g^2 are set-screws for locking the pivot-screws g' after they have been properly adjusted. g^3 are lugs depending from the oscillating plate g and having curved working surfaces sliding upon the curved cheeks g^4 of the traveler f , in order to avoid undue sidewise play of the oscillating plate g . The plate g is normally retained in contact with the traveler f by means of a spring g^5 , fitted into a recess g^6 in the end wall of the traveler and adapted to engage a lip g^7 upon the cover or end plate g^8 of the oscillating plate g . The oscillating plate g is rotated about the pivotal screws g' by means of a cross-head g^9 , which is shifted between the wedge-shaped cheeks or ways g^{10} upon the traveler and oscillating plate. This cross-head g^9 is actuated by a spindle h , having a threaded extremity in engagement with a suitable nut formed integral with or suitably attached to the cross-head. The shank of the spindle h works freely in a suitable recess formed between the traveler and oscillating plate and extending through the bead f^4 . The shank of this spindle is provided with a hand-screw h^2 , attached thereto by means of a key h' , engaging a keyway, and also by means of a screw h^3 , inserted into the extremity of the spindle h and having the head thereof in engagement with the hand-screw h^2 . This spindle is held against end-play by

means of an end plate h^4 , attached to the oscillating-plate g . Moreover, this end plate h^4 is afforded a range of oscillating motion with reference to the spindle by means of a ball-and-socket joint. The ball portion h^5 of this joint is formed or cut upon the end plate h^4 and is centrally perforated for the passage of the spindle h . The socket portion of this joint is made in two parts, whereof one is formed upon the hand-screw h^2 and the other upon a gasket h^6 , mounted on the spindle and held to place by means of a flange h^7 , so that the rotation of the hand-screw h^2 causes the spindle h to shift the cross-head g^9 , and the movement of the cross-head g^9 causes the oscillating plate g to be slightly rotated about the pivot-screws g' , and the ball-and-socket joint h^5 between the end plate and the spindle permits this rotary motion of the oscillating plate to take place independently of the shank of the spindle h . The upper surface of the oscillating plate is provided with an internally-expanded slot i , into which the foot i' of the tool-post i^2 is first fitted and then clamped by means of the washer i^3 , tool a , and set-screw i^4 .

The mode of operation of the hereinabove-described apparatus is as follows: The point of the tool a may be raised or lowered in a vertical plane by rotating the oscillating plate g in a similar plane by shifting the cross-head g^9 in one direction or the other by the rotation of the hand-screw h^2 . The point of the tool a may be turned in a horizontal plane by first rotating the handles e^2 of the spindles e^2 , whereby the dogs e are caused to unclamp the sliding plate c and rotating plate d , and then turning the plate d about the pivot c^7 , whereupon the plates c and d may be again clamped together by turning the handles e^2 of the spindles in a reverse direction. The tool a may be fed with reference to the bed-plate b by rotating the handle b^8 , whereby the sliding plate c and parts connected therewith, including the rotating plate d , traveler f , oscillating plate g , and the tool a , are shifted. The tool a may be fed with reference to the rotating plate d by rotating the handle d^{11} , whereby the traveler f and parts connected therewith, including the oscillating plate g and tool a , are shifted. The two feed motions and the two rotary motions enable the operator to shift the point of the tool a into any required position for operating upon the work, and the peculiar construction and arrangement of the adjustments and attachments, hereinabove described, enable these motions of the tool to be accomplished with great rapidity and accuracy.

It will be obvious to those skilled in the art to which the invention relates that modifications may be made in detail without departing from the spirit of the invention, and hence I do not limit myself to the exact construction and arrangement hereinabove set forth; but,

Having thus described the nature and ob-

jects of my present invention, what I claim as new, and desire to secure by Letters Patent, is—

1. In a tool-rest, a bed-plate provided with an aperture terminating in a seat, a feed-screw afforded a range of end-play in said aperture and having one extremity adapted to fit said seat and the other extremity provided with a flange, a collar and a handle, a nut rigidly attached to the bed-plate by a key and slot and engaging said screw, a sliding plate working in ways on said bed-plate, and a yoke pinned and screwed to said sliding plate and interposed between said collar and flange, substantially as and for the purposes set forth.

2. In a tool-rest, a bed-plate provided with a recess, a sliding plate working in ways on said bed-plate, a fixed nut attached to said bed-plate, a feed-screw afforded a range of end-play in said recess and provided with a flange and a threaded exterior extremity, a collar screwed onto the threaded extremity of said feed-screw, a set-screw in said collar, a yoke attached to said sliding plate and interposed between said collar and flange, and an operating-handle connected with said feed-screw, substantially as and for the purposes set forth.

3. In a tool-rest, a sliding plate provided with a socket, a rotatable plate provided with a pivot, an annular bearing-flange and an internally-expanded annular slot, clamping devices engaging said expanded slot and sliding plate, and means for actuating said clamping devices, substantially as and for the purposes set forth.

4. In a tool-rest, a sliding plate, a rotating plate pivoted thereto and provided with an internally-expanded annular slot, dogs having the heads thereof in engagement with said slot and having perforated shanks fitted into recesses in said sliding plate, spindles provided with handles and cams and fitted into apertures in said sliding plate, and screws inserted axially into the shanks of said dogs and engaging said cams, substantially as and for the purposes set forth.

5. In a tool-rest, a sliding plate, a rotating plate pivoted thereto and provided with an internally-expanded annular slot, dogs working in apertures in said sliding plate and provided with flattened heads engaging the expanded portion of said slot, and spindles working in apertures in said sliding plate and provided with cams engaging said dogs, substantially as and for the purposes set forth.

6. In a tool-rest, a sliding plate, dogs working in apertures in said plate and provided with heads, cams for actuating said dogs, means for operating said cams, and a rotating plate pivoted to said sliding plate and provided with an internally-expanded annular slot having a portion of the front wall thereof broken away to permit of the insertion of the heads of the dogs into said slot, substantially as and for the purposes set forth.

7. In a tool-rest, two plates, whereof one is

provided with ways and the other with a recess for engaging said ways, a strip interposed between said ways and recess, set-screws for adjusting said strip laterally, and pins interposed between said strip and recess and working in apertures to permit of the lateral adjustment of said strips and to prevent end-play thereof, substantially as and for the purposes set forth.

8. In a tool-rest, a rotating plate provided with a slot extending to but not through the extremities thereof and communicating with an interior chamber, a feed-screw rotatably mounted in said chamber, a handle for rotating said feed-screw, a transversely-ranging opening formed in the side wall of said slot and provided with a removable cover, a traveler sliding in ways on said plate, and a nut engaging said screw and having the shank thereof inserted into said slot through said opening and attached to said traveler, substantially as and for the purposes set forth.

9. In a tool-rest, a rotating plate provided with a slot extending to but not through the extremities thereof and communicating with an internal chamber extending through only one end of said plate, a bearing at the closed end of said chamber, a screw-bushing inserted into the open end of said chamber, a feed-screw mounted in said chamber and having one extremity supported in said bearing and the other extremity supported in said bushing, an opening ranging transversely of one of the side walls of said slot, and a nut engaging said screw and having the shank thereof inserted into said slot through said opening and connected with a traveler, substantially as and for the purposes set forth.

10. In a tool-rest, a rotating plate having one edge provided with a longitudinally-ranging slot communicating with an internal chamber and one face provided with a transversely-ranging slot having a removable cover for permitting of the insertion of a nut, substantially as and for the purposes set forth.

11. In a tool-rest, a rotating plate having one edge provided with a slot communicating with an internal chamber and one face provided with a transversely-ranging slot, a bushing in said chamber, a removable cover connected with said transverse slot, and a screw engaging said cover and bushing, substantially as and for the purposes set forth.

12. In a tool-rest, a traveler, an oscillating plate pivoted thereto, means for normally retaining said plate in a depressed position, a movable cross-head interposed between said plate and carrier, and means for shifting said cross-head, substantially as and for the purposes set forth.

13. In a tool-rest, a traveler provided with a bead and with curved cheeks, an oscillating plate pivoted to said bead by screw-pivots and provided with lugs having curved working-surfaces in engagement with said cheeks,

means for normally retaining said plate in a depressed position, and a movable cross-head interposed between said plate and traveler, substantially as and for the purposes set forth.

14. In a tool-rest, a traveler, an oscillating plate pivoted thereto and normally retained in a depressed position, a cross-head interposed between said plate and traveler, a rotatable spindle having a threaded shank engaging a nut on said cross-head, an end plate on said oscillating plate provided with an aperture for the passage of said spindle, and a ball-and-socket joint between said end plate and spindle, substantially as and for the purposes set forth.

15. In a tool-rest, a cross-head provided with a nut, a spindle having a threaded extremity engaging therewith, a plate for preventing endwise motion of said spindle, a perforated ball on said plate, a washer provided with a socket and supported by a flange on said spindle, and a hand-screw provided with a socket and mounted on said spindle, substantially as and for the purposes set forth.

16. In a tool-rest, a traveler provided with a recess, a spring in said recess, an oscillating plate pivoted to said traveler, and a plate provided with a lip for engaging said spring and attached to said oscillating plate, substantially as and for the purposes set forth.

17. In a tool-rest, a traveler provided with a bead having journals or seats therein, an oscillating plate provided with side flanges, screw-pivots engaging said side flanges and seats, and set-screws for locking said screw-pivots, substantially as and for the purposes set forth.

18. The herein-described tool-rest, comprising a bed-plate provided with a feed-screw having a handle, a sliding plate mounted on said bed-plate and provided with a yoke engaging said screw, a rotating plate provided with a feed-screw having a handle and pivotally connected with said sliding plate, means for clamping said rotating and sliding plates together, a traveler on said rotating plate provided with a nut engaging the rotating-plate feed-screw, an oscillating plate pivotally attached to said traveler and normally in contact therewith, a cross-head provided with a nut, a spindle connected with the oscillating plate by a ball-and-socket joint and having a hand-screw and a threaded extremity in engagement with said nut, and a tool and tool-post attached to said oscillating plate, substantially as and for the purposes set forth.

In witness whereof I have hereunto set my signature in the presence of two subscribing witnesses.

EDWARD STEWART STEHMAN.

Witnesses:

THOMAS M. SMITH,
HERMANN BORMANN.